

TS 324 MPS 60X-3 SERIES STANDARD MOVABLE CLIP

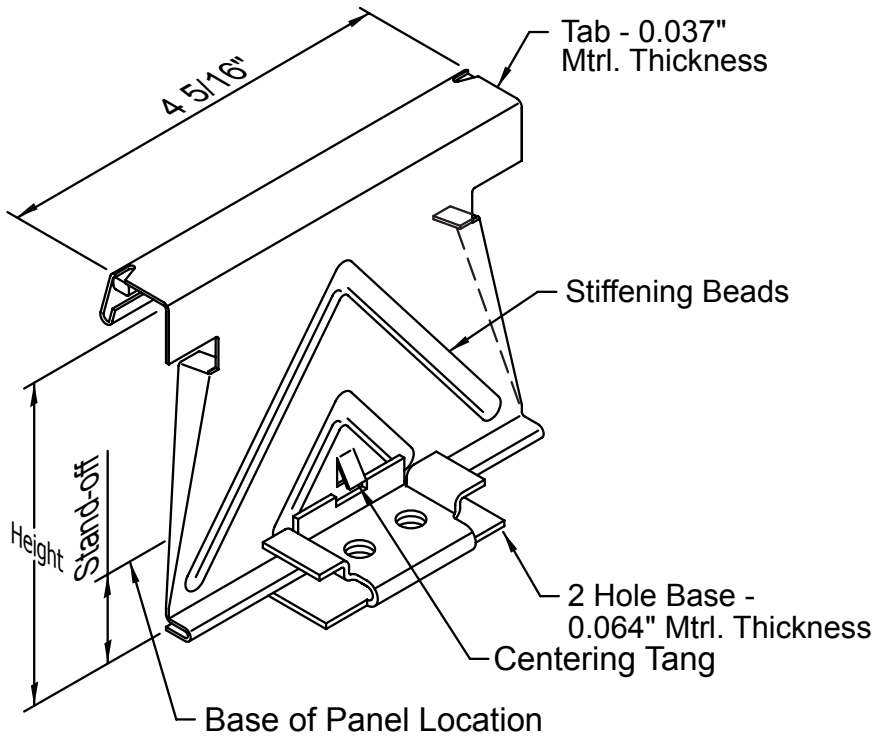

| Part # | Stand-Off | Height |
|-----------|-----------|--------|
| MPS 602-3 | 1/2" | 3-1/2" |
| MPS 603-3 | 1-1/2" | 4-1/2" |

CONSTRUCTION, TESTING, SEAMING

- G-90 Galvanized 50 ksi Steel Coating
- Centering Tang
Fixed at center for installation
Free thermal movement after installation
- UL 90 Approved: Construction # 552, 552A and 552B
- ASTM E 1592 Wind Uplift Tested
- Three Mechanical Seam Options: RollLok®, TripleLok® and QuadLok®

THERMAL MOVEMENT

| Clip Part # | Base Holes | Slide One Way | Maximum Length Plane Without Expansion Design | | |
|------------------|------------|---------------|---|-----------------------|-----------------------|
| | | | Temp Diff 100 degrees | Temp Diff 125 degrees | Temp Diff 150 degrees |
| MPS 60X-3 Series | 2 | 1.325 | 170' - 0" | 135' - 0" | 115' - 0" |



The Superior Seam Technology design and engineering meets the more stringent corner/edge zones uplift codes.