

INDEX

1.0 General Overview
 1.1 Installation Methods 1-1

2.0 Roof Opening – Sheet-in
 2.1 Sheeting the Roof 2-1
 2.2 Recommended Procedure..... 2-1
 2.3 Safety Note 2-1

3.0 Roof Opening – Retro-fit
 3.1 Sheeting the Roof 3-1
 3.2 Opening Cut Requirements 3-1
 3.3 Quadlok Side Seams 3-1

4.0 Sub-Framing
 4.1 Recommended Procedure..... 4-1
 4.2 Purlin Span Note 4-1
 4.3 Sub-framing Package 4-1
 4.4 Sub-framing Intent 4-1
 4.5 Alignment Channels 4-2
 4.6 Side Channel Attachment 4-2

5.0 Insulation Retention
 5.1 Retainer Strip Sequence 5-1
 5.2 Downhill Retainer 5-1
 5.3 Uphill Retainer 5-1

6.0 Seam Prep
 6.1 Open a Quadlok 6-1
 6.2 Detail Locator 6-1
 6.3 Watertightness Note 6-2
 6.4 Seam Drilling 6-2
 6.5 Proper Fit 6-2
 6.6 Corner Prep 6-3

7.0 Dry Fit
 7.1 Uphill Panel Positioning 7-1
 7.2 Curb Placement 7-1

8.0 Sealant Application
 8.1 Uphill Sealant Application 8-1
 8.2 Downhill Sealant Application 8-2

9.0 Curb Installation
 9.1 Uphill Panel Positioning 9-1
 9.2 Retro-fit Seam Caulking 9-1
 9.3 Curb Placement 9-1

10.0 Uphill Fastener Placement
 10.1 Fastening Sequence 10-1
 10.2 No Fastener Zone Warning 10-1

11.0 Side Seam Cap Installation
 11.1 Pre-Drill cap 11-1
 11.2 Sealant Application 11-1
 11.3 Side Seam Cap Placement 11-1
 11.4 Secure Uphill Insulation 11-1

1.0 GENERAL OVERVIEW

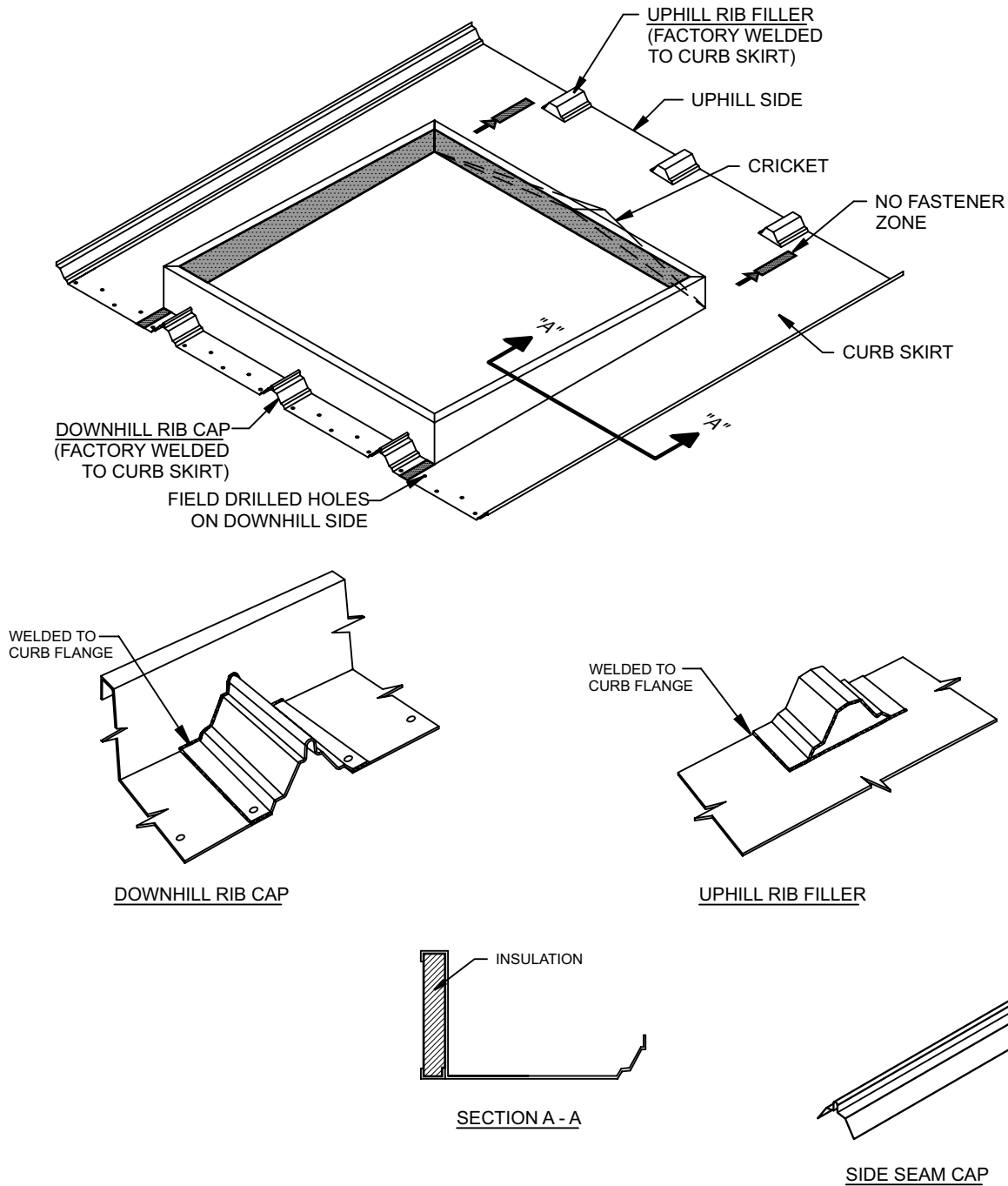

1.1 Installation methods

This installation procedure is for the curb to be “sheeted in” during the roof panel installation or as a retrofit option where the roof opening will be cut after the roof is sheeted and seamed. The installation process for the “shingle”

procedure is the uphill end goes under the roof panel and the downhill end goes over the panel.

2.0 ROOF OPENING (SHEETED IN)

WARNING!
ALWAYS USE FALL PROTECTION
WHILE WORKING AROUND ROOF
OPENINGS

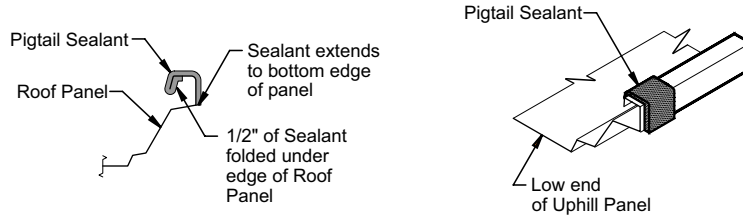

PIGTAIL SEALANT DETAIL

①②③ etc. - Denotes Left to Right Sheeting Sequence (Right to Left is Opposite)
UPHILL END

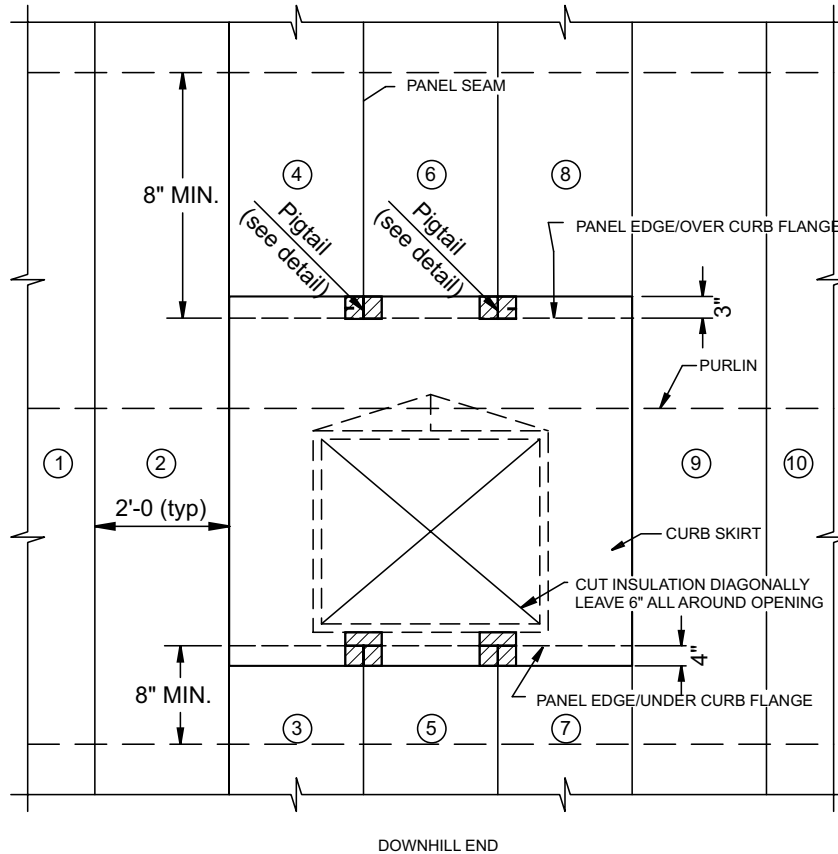

2.1 Sheeting the Roof

Sheet the roof according to building manufacturers procedure up to the side flange location of the curb. Continue to sheet **factory cut to length panels** around the opening

in the correct sequence. **Important.** During the sheeting process be sure to install pigtails at all uphill panel seams. **It is critical to maintain accurate module spacing.**

2.2 Recommended Procedure

The roofing crew can continue at this point. A second crew should begin final curb prep and installation

2.3 Safety Note

Important While working on and around the curb opening always use walk boards and fall protection. Do not leave

the opening without taking safety first and keep all walk boards in place.

3.0 ROOF OPENING (RETROFIT)

WARNING!
ALWAYS USE FALL PROTECTION WHILE WORKING AROUND ROOF OPENINGS

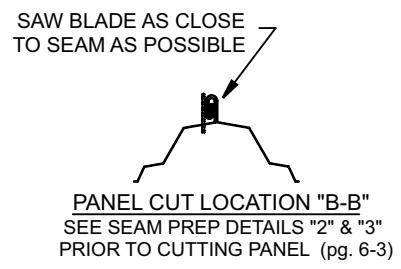
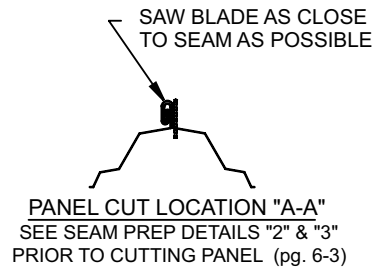
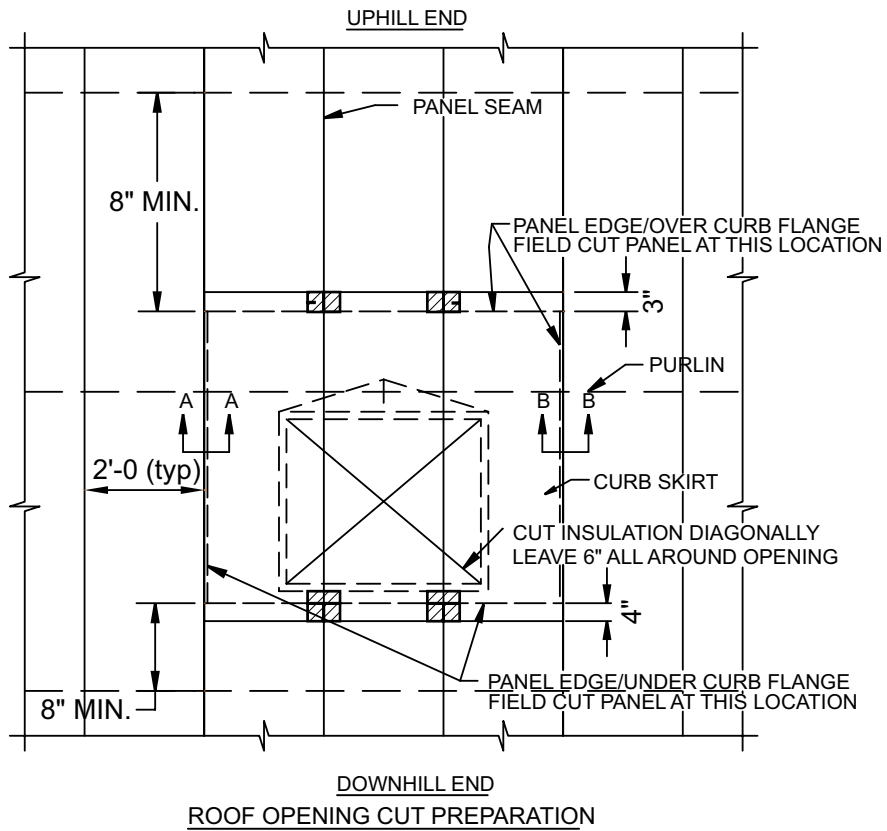

3.1 Sheeting the Roof

The roof should be sheeted solid at this point and according to building manufactures procedure. You will need to

prepare the opening with saw cuts and pre locating the opening area to cut.

3.2 Opening Cut Out Requirements

The curb width will always run panel seam to panel seam. A simple way to determine the curb and cut location is to set the curb onto the roof with a minimum of 0'-8" from the nearest downhill purlin and a minimum of 0'-8" from the up-

hill purlin. Mark the corners of the curb then make the cross cuts at 0'-4" above the lower corner marks and 0'-3" below the up hill corners marks. **Cut insulation on diagonal. Be sure to leave 6" reveal all around.**

3.3 Quadlok Side Seams

Each side seam needs to be made Quadlok but **do not extend beyond** the curb length at this time. Only extend to the edge of the cross cut. Using a Skill type saw with a metal cutting blade you need to make the cross cut first, and then using extreme caution (walk boards in place) cut

along each seam and as close as possible to the inside of each seam. For your safety, remove the cut section, then clean and deburr all around the cut area to eliminate any raw and disturbed metal. (Reference page 6-2 detail for seam prep prior to QuadLoking the side seam at the uphill and downhill ends.)

3.4 Safety Note

Important While working on and around the curb opening always use walk boards and fall protection. Do not leave

the opening without taking safety first and keep all walk boards in place

4.0 SUB FRAMING

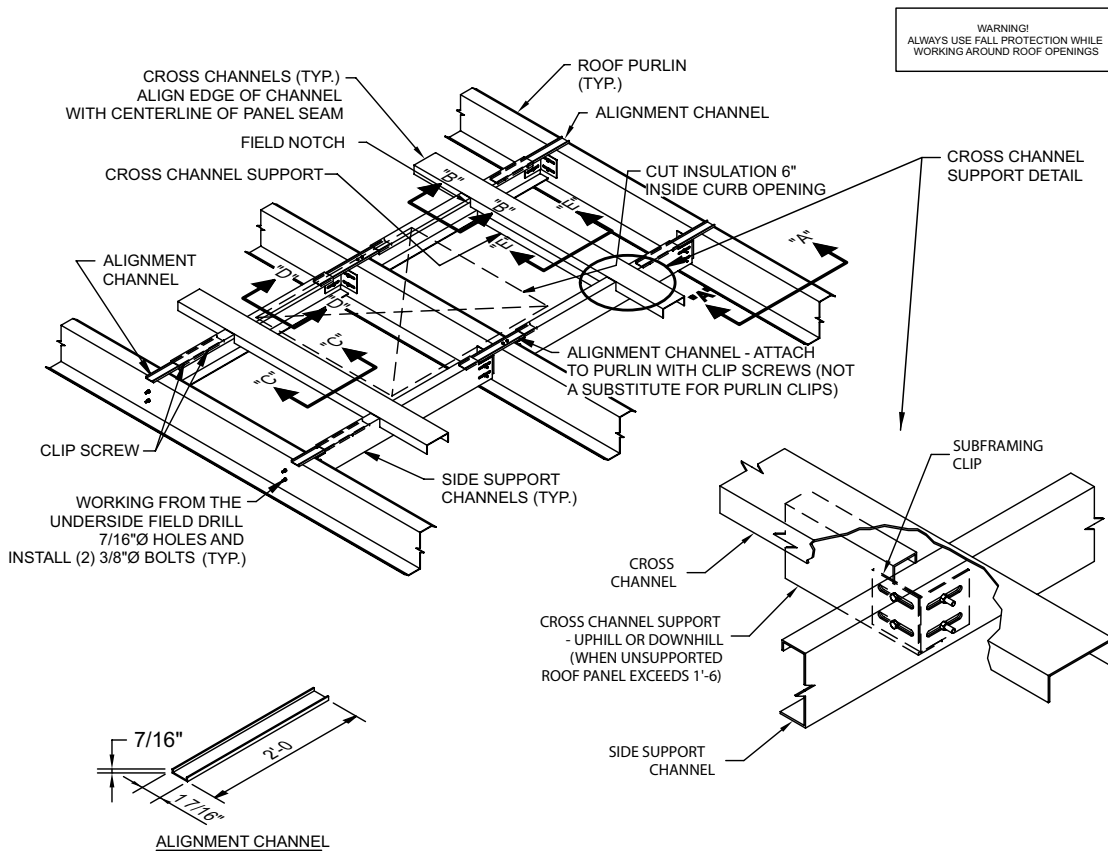

4.1 Recommended Procedure

At least two men are recommended to install the curb and sub-framing, one man to work the underside and the other(s) above the roof.

4.2 Purlin Span Note

Most applications will require a minimum of two purlin spans or more. All references here after are for a minimum of two

span. Additional spans are similar.

4.3 Sub-framing Package

The sub frame package consists of slotted side support channels, factory notched cross channels, alignment channels, curb support clip and hardware. **Wind uplift tie**

down clips are an option and are normally required on curbs supporting light weight accessories such as a skylight or roof hatch. Design and material of tie-down clips to be provided by Licensee.

4.4 Sub-framing Intent

The intent of the sub frame is to provide support to the curb only and should **never** restrain the sliding motion. The intent is to allow the curb to float and move back and forth with the roof as thermal movement is experienced. Every

precaution has been designed into the curb to prevent this from happening. Gravity loads will hold the curb unit down unless special uplift tie downs are required. **Uplift and overturning should be checked by an engineer.**

4.0 Sub Framing (Continued)

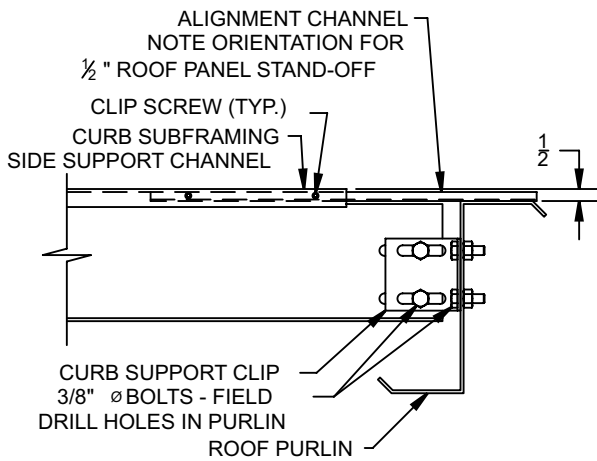

SECTION "A"
1/2" Roof panel Stand-off

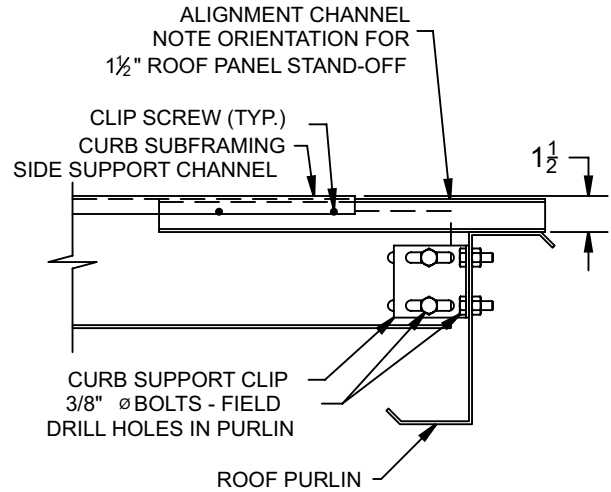

SECTION "A"
1 1/2" Roof panel Stand-off

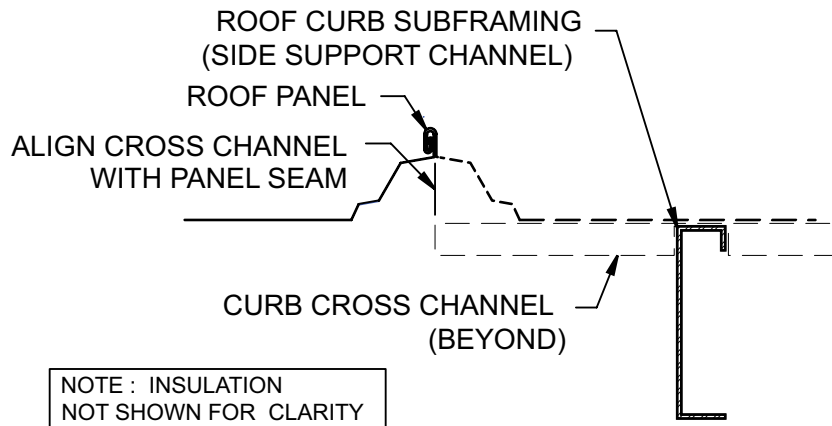

SECTION "B"

4.5 Alignment Channels

Begin by attaching alignment channels to the side support channels. Allow enough run by to comfortably rest on the roof purlin. Be sure to turn the alignment channel in its proper position as it is designed to work with either 1/2" or

1-1/2" panel standoff. This will allow the side support channels to "hang" on the purlin and free up your hands to locate, drill and install the curb support clips and bolts.

4.6 Side Channel Attachment

To properly locate the side channels, temporarily set the factory notched cross member onto the side channel and align the end of the cross channel with each panel seam.

Make sure clearance is accounted for to allow the cross member to easily slide without binding.

5.0 INSULATION RETENTION

5.1 Retainer Strip Sequence

To install the insulation retainer strips be sure to only install the two sides and downhill end at this time. Start with the side channel and remove 3" of the batt insulation and then

pull the 3" vapor barrier over the side channel and secure with the insulation retainer strip and self drilling screws.

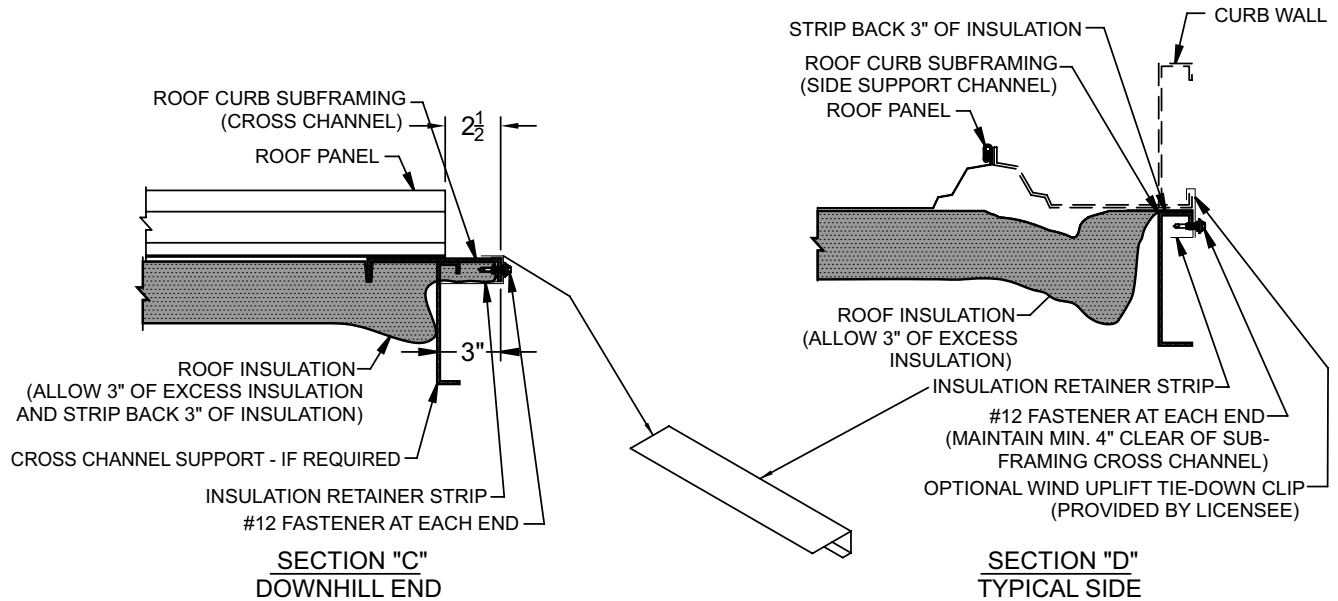

5.2 Downhill Retainer

At the downhill end, strip back 3" of batt insulation then push the excess 3" insulation downhill while maintaining a 2-1/2"

reveal on the cross support. Then pull the vapor barrier over the cross member and secure retainer with S.D. drillers.

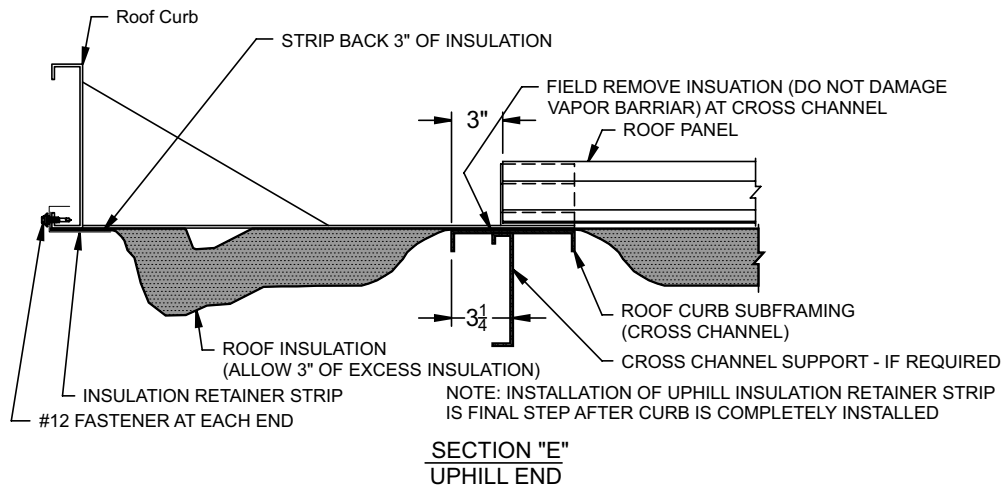

5.3 Uphill Retainer

The uphill end can only be done after the curb has been set in place. First, strip the batt insulation away at the cross member and pull over the cross member for support. Next is stripping 3" of batt insulation at the curb wall. While push-

ing the 3" excess insulation flush with the inside of the curb flange, pull the vapor barrier to the curb wall and fasten the retainer through the curb wall flange with Self Drillers.

6.0 SEAM PREP PROCEDURE

6.1 Open a Quadlok

The seam style will more than likely be TripleLok at the roof panel end. If not then the seam must be opened in order to drill and seal. This can be accomplished using vice grips as shown.

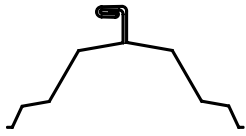

TRIPLELOK SEAM

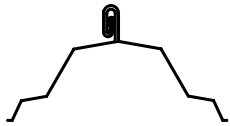

QUADLOK SEAM

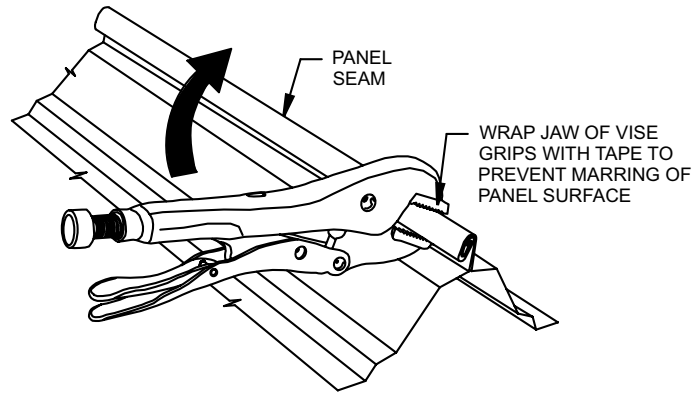

TO OPEN A CLOSED (QUADLOK) SEAM FOR DRILLING....

6.2 Detail Locator

The following detail locator shows the specific details to refer to and the seam treatment and special sealant treatment all around the opening.

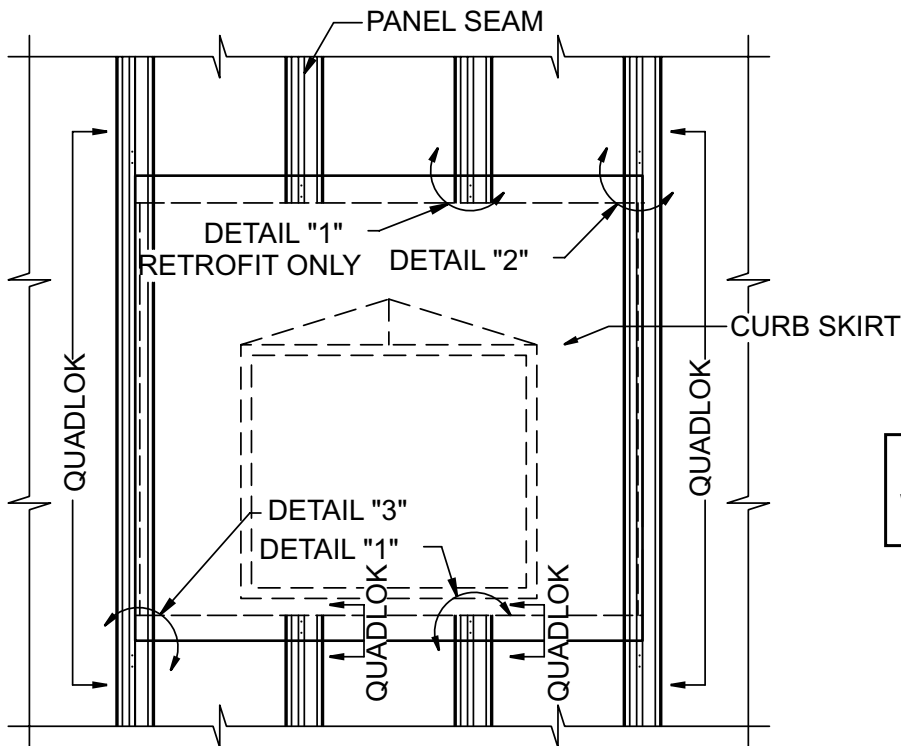

WARNING!
ALWAYS USE FALL PROTECTION
WHILE WORKING AROUND ROOF
OPENINGS

6.0 SEAM PREP (CONTINUED)

6.3 Watertightness Note

These next few steps are critical to the water tightness and integrity of the entire installation. Each is considered **essential**. If the following details are not adhered to then the system is void of all test values and warranties and cannot be warranted as a 20 weather tight system.

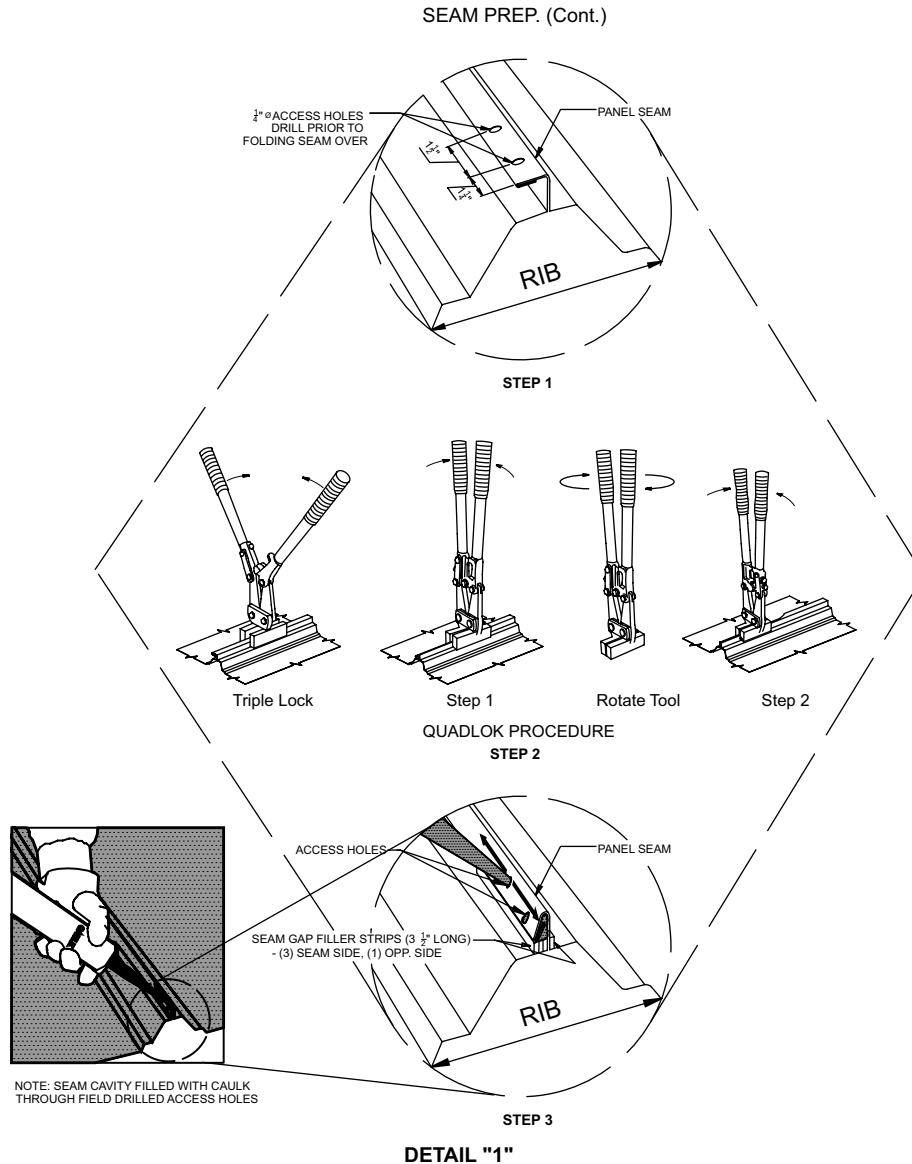

6.4 Seam Drilling

The panel seam is to be drilled with 1/4" holes. Drill all the way through the seam as shown on step 1 detail 1. Fold the seam to 180° (Quadlok) and then fill the seam gap with strips of 1/4" bead sealant. Finally, force fill the access holes

with caulk and continue until you see signs of the caulk protruding beyond the holes.

Note. Detail 1 does not apply, in the "sheeted in" option, to the uphill end installation when the pigtail is in place.

6.5 Proper Fit

In order for the roof curb to fit properly the last 8" of the seam must be turned down to 180 degrees (QuadLok) above and below the opening. This will be accomplished

with hand seamers and the operation of these seamers is as shown above.

6.0 SEAM PREP (CONTINUED)

6.6 Corner Prep.

To prepare the side seams for the seam cap will happen at all four corners of the detail. The preparation is the same drill and fill but requires different set back dimensions. The set back at the uphill end is 6 1/4" while the downhill is

7 1/4". The finished QuadLok seam should be a minimum of 1'-0" above and below the panel opening. Install (3) strips of seam gap fillers 9" & 10" long to fill void as shown on Detail 2 and 3.

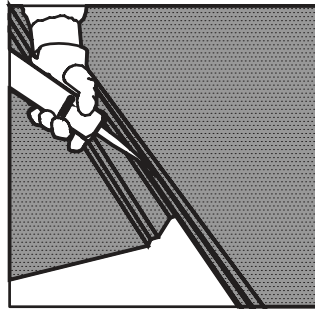
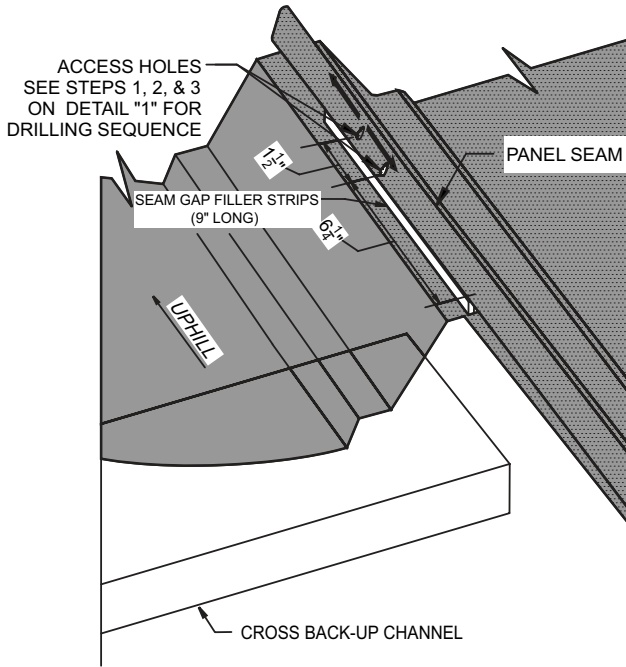

NOTE: SEAM CAVITY FILLED WITH CAULK THROUGH FIELD DRILLED ACCESS HOLES

DETAIL "2"
UPHILL

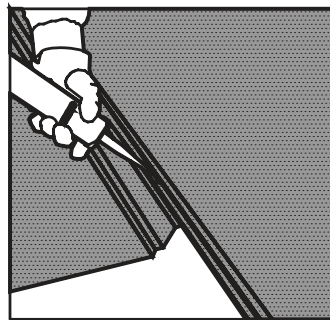
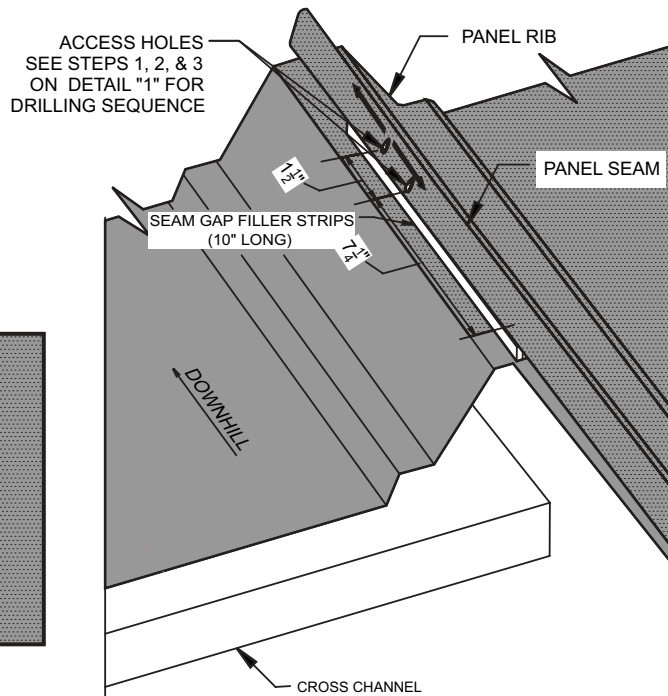

NOTE: SEAM CAVITY FILLED WITH CAULK THROUGH FIELD DRILLED ACCESS HOLES

DETAIL "3"
DOWNHILL

7.0 DRY FIT

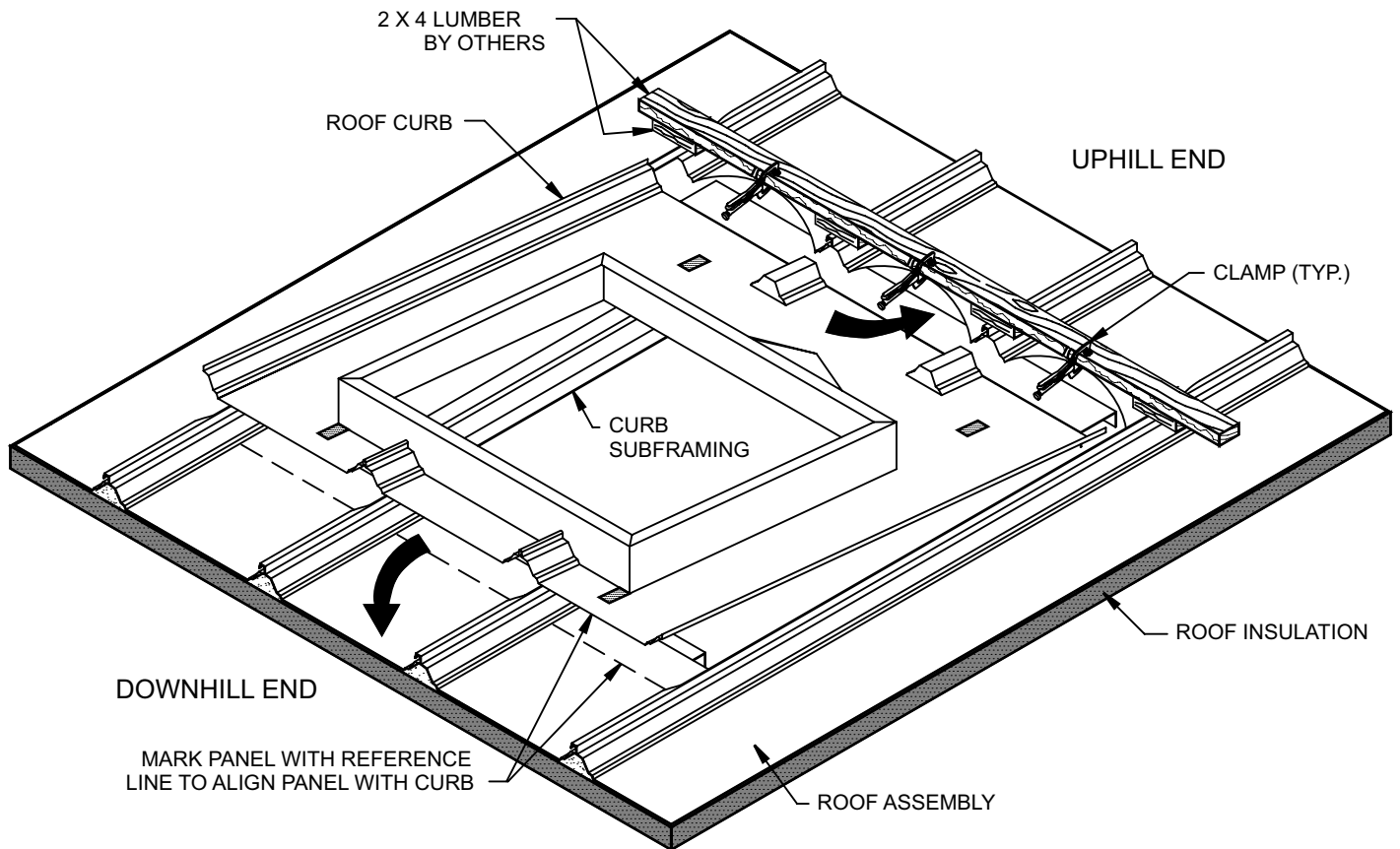

WARNING!
ALWAYS USE FALL PROTECTION
WHILE WORKING AROUND ROOF
OPENINGS

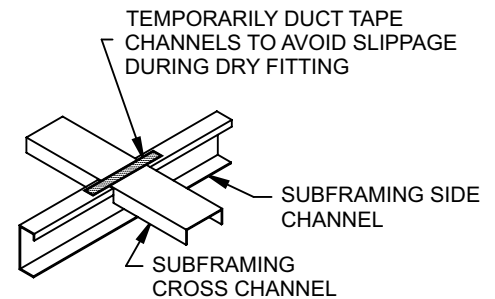

7.1 Uphill Panel Positioning

At this point a dry check of the roof curb into the opening is a good idea. To do this position some 2x4 stock at the uphill

end and using clamps to pull the flat of each panel upward. It is recommended to use clamps with swivel feet.

7.2 Curb Placement

Slip the curb unit into place and check alignment of side channels to the curb wall to assure they are straight and squarely located under the curb wall. Check the cross members and temporarily tape the over lap to the side

channels. Make sure the side seams fit and are aligned. Make adjustments as required and mark the edge location of the down hill skirt edge. Remove the curb to begin sealant preparation.

8.0 CURB SEALANT APPLICATION

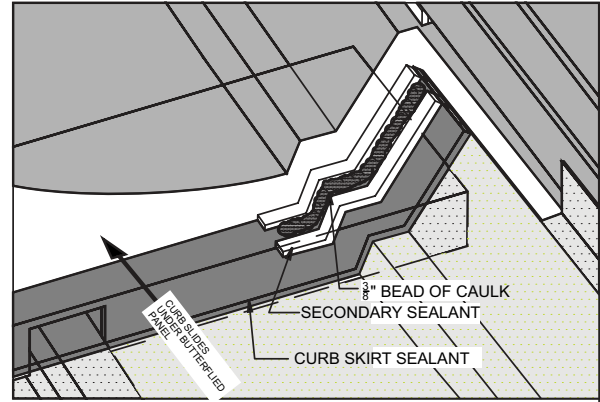

CORNER DETAIL

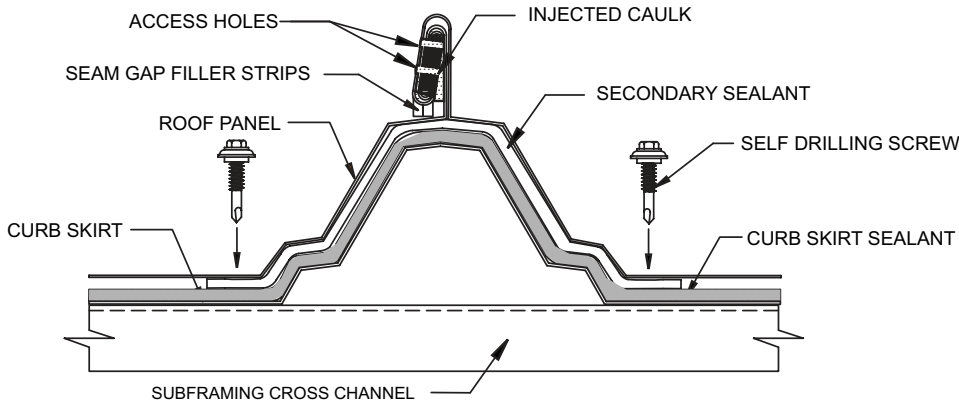
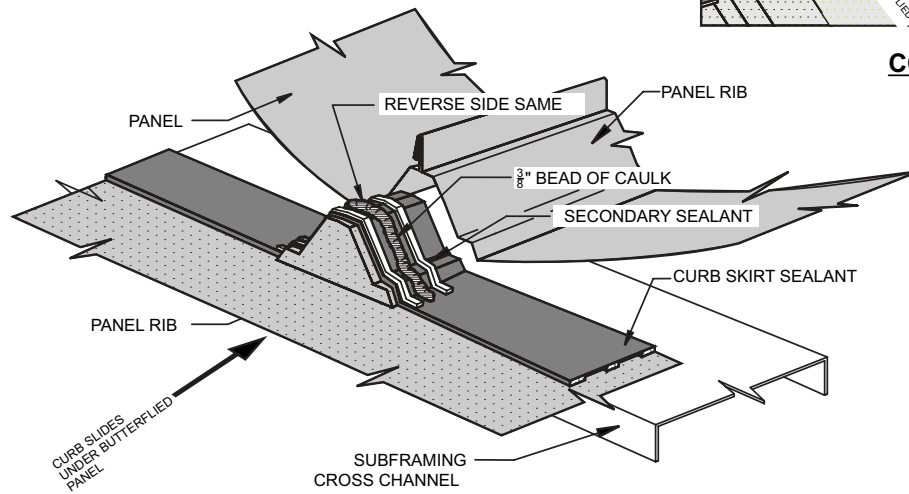

SEALANT DETAIL "1"
UPHILL END OF CURB

8.1 Uphill Curb Sealant

Apply triple bead sealant to the uphill end of curb flange as shown in Detail 1. Align the edge of the backer paper to the edge of the curb skirt and continue up and over the rib filler. It is good to “work” the sealant into the tight corners as you go leaving the backer paper on.

ant, then at each rib apply two strips of 1/4” bead sealant using two beads of the triple bead as a guide. Between the two strips apply a bead of caulking that will fill all the minute spaces as shown in detail 1. Repeat at each available rib filler inside the opening. Be sure to finish out the corners in the same manner.

Remove the backer paper slowly as to not upset the seal-

8.0 CURB SEALANT APPLICATION (CONTINUED)

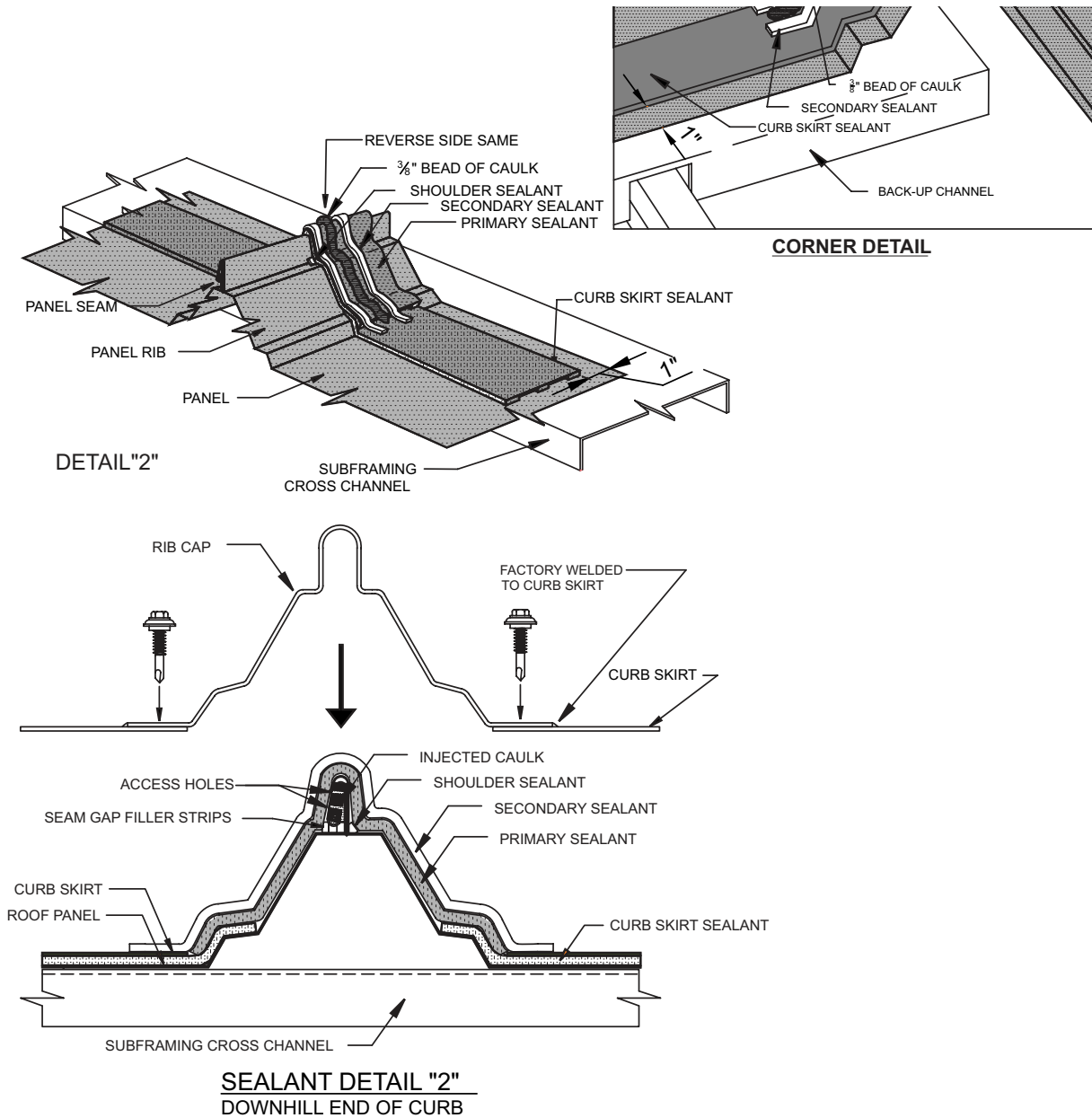

8.2 Downhill Curb Sealant

Apply triple bead sealant to the uphill end of the downhill panel as shown in Detail 2. Align the edge of the backer paper 0-1" back from the edge of the panel and continue up and over each panel rib. It is good to "work" the sealant into the tight corners as you go with the backer paper in place.

Remove the backer paper slowly from triple bead sealant. Then at each rib apply two strips of 1/4" bead sealant as shown in the detail using two beads of the triple bead as a guide. Between the two strips apply a bead of caulk as a secondary sealant that will fill all minute spaces as shown in Detail 2. Repeat at each available rib inside the opening and each corner.

9.0 CURB INSTALLATION

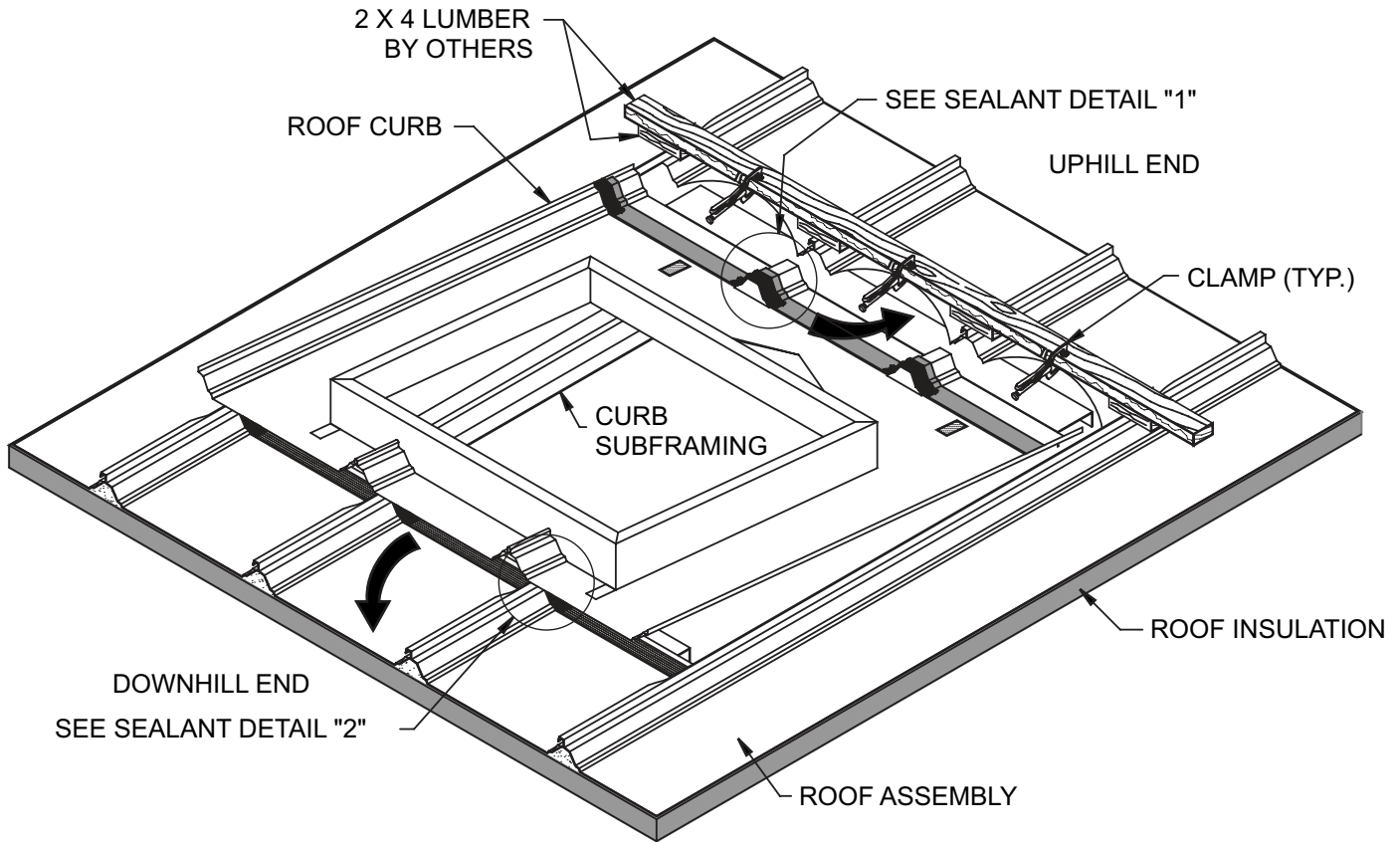

WARNING!
ALWAYS USE FALL PROTECTION
WHILE WORKING AROUND ROOF
OPENINGS

9.1 Uphill Panel Positioning

The curb and opening prep is complete and the curb is now ready to install. Begin by making a 2x4 cripple to lift the uphill flats of the roof panel. Use vise grip clamps with swivel feet

to clamp the panels to a “butterfly” position which allows space for the curb to slip under the roof system.

9.2 Retrofit Requirement

While the panel is “butterflied” open, inject caulking into the seam stem. Ensure that the caulking fully extends to the

top of the seam. (This step is not required for the sheet-in option, with the pigtail installed.)

9.3 Curb Placement

Slide the entire curb assembly into the opening with the uphill end pointed downward and riding on the side support members. Care should be taken to slowly work the uphill end under the panel and not disturb the sealant placement.

Once the curb unit is under the panel and the unit is square in the opening lower, the downhill end into place. At this time temporarily clamp with vise grips the panel side seam to the upturn leg of the curb.

10.0 UPHILL FASTENER ATTACHMENT

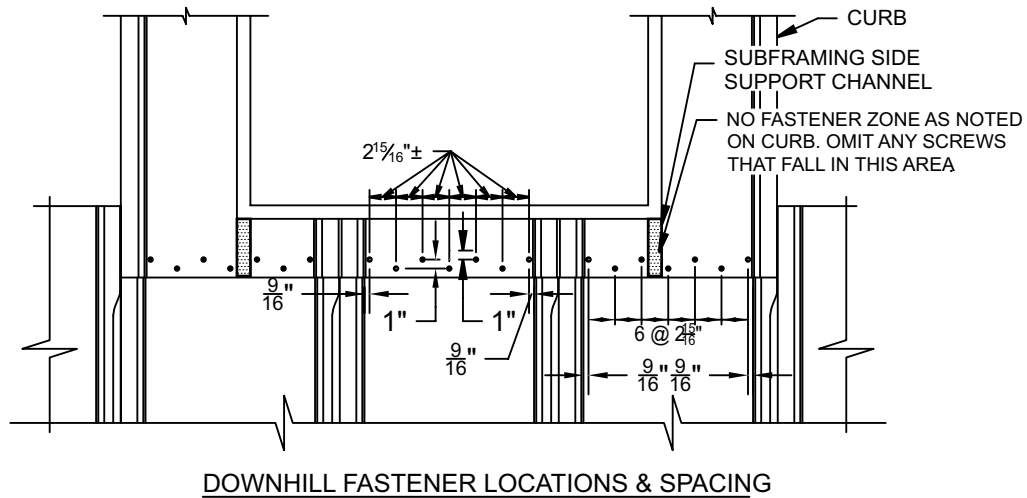
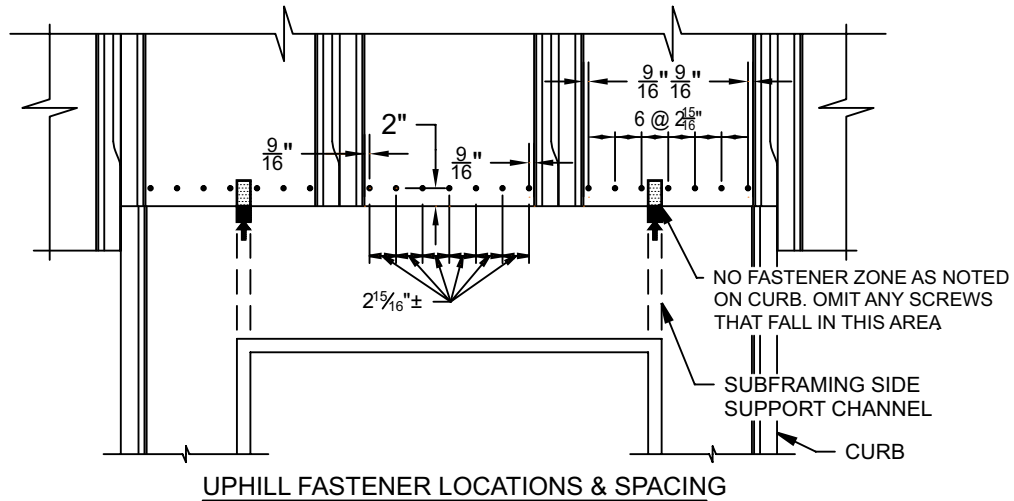

10.1 Fastening Sequence

Release the cripple and begin to slowly walk the panel down onto the curb. Install roof fasteners at spacing as described in this illustration. Be sure to walk down each connection

at each rib and install fasteners first on either side of the rib. Then fill between with fasteners spaced as shown in this illustration.

10.2 No Fastener Zone Warning

Repeat process at the lower end through factory punched holes making sure not to put fasteners in the "no fastener" zone.

11.0 SIDE SEAM CAP INSTALLATION, COMPLETE THE INSTALLATION

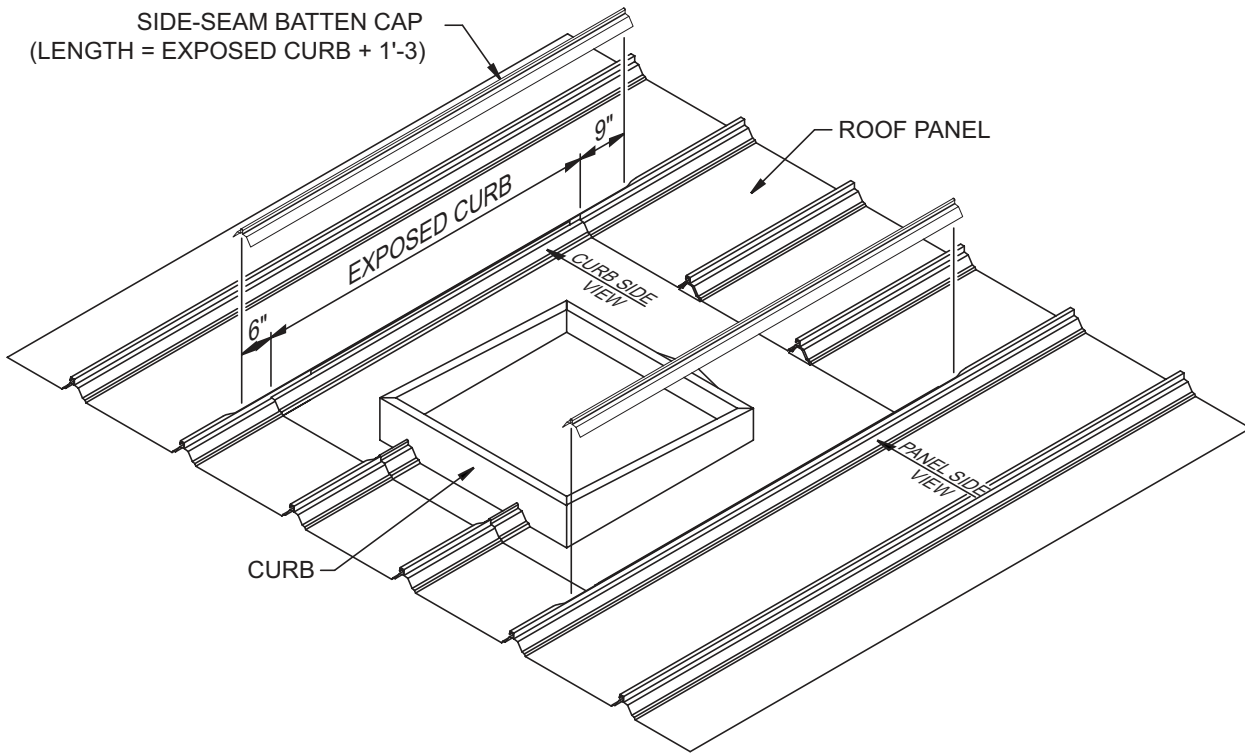

WARNING!
ALWAYS USE FALL PROTECTION
WHILE WORKING AROUND ROOF
OPENINGS

11.1 Pre-drill Side Seam Cap

Installing the seam caps and fasteners... First pre-drill attachment holes in the seam cap at 0"-1" then 3 3/4" then 7 1/4" in from each end then maximum 1'0 centers using the score line as the straight line. Do this on the side facing

the curb. On the opposite side facing away from the curb start 0-1" then 0-11" in from each end then 1'-0 maximum centers on the score line. [See Page 11-2](#)

11.2 Sealant Application

Apply 1/4" sealant along the lower inside edge and along the length on each side of the seam cap, and then bridge each end as shown on the detail with two strips of 1/4" sealant at 2" apart. Between those two strips add caulk at both ends.

An additional bead of 6" caulk will be required at the downhill end to bridge material thickness difference at curb side. ["See Curb Side View" Page 11-2](#)

11.3 Side Seam Cap Placement

Mark a 9" run by at the uphill end and a 6" run by at the lower end. Set the cap to these marks and slowly press downward while installing stitch fasteners at pre-drilled locations.

Slowly seat the fastener to allow sealant to flow. It's recommended to repeat the tightening procedure several minutes later to insure good sealant flow.

11.4 Secure Uphill Insulation

The last step is to secure the roof insulation at the curb apron if you haven't already. (Section "E", pg. 5-1)

11.0 SIDE SEAM CAP INSTALLATION, COMPLETE THE INSTALLATION (CONTINUED)

