

# TS-324 PERFORMANCE

## TripleLok®

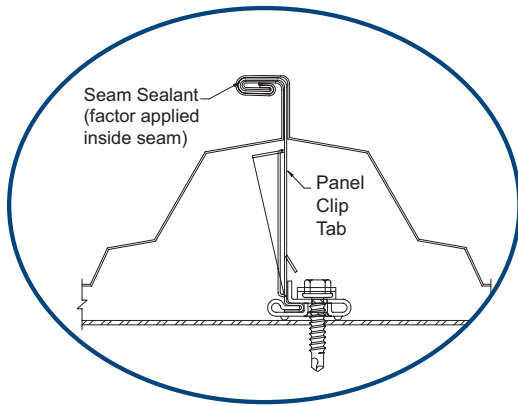

## QuadLok®

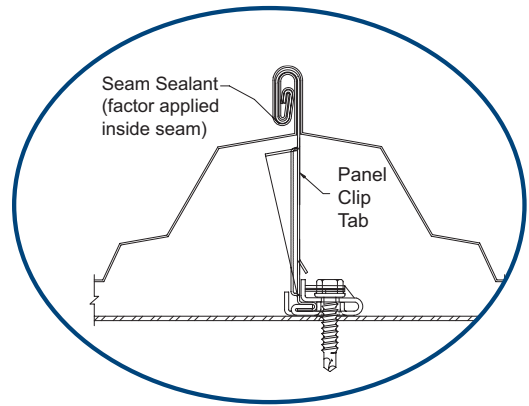

RollLok® option available

## Third Party Testing Performance

### ASTM E 1680-95 (2003)

Test Number	Static Pressure Difference	Air Infiltration Rate	
	psf	cfm/ft <sup>2</sup>	dfm/lin.ft
1	1.57	0.0007	0.0015
2	6.24	0.0018	0.0035
3	30.00	0.0042	0.0083
4	40.00	0.0046	0.0093

### ASTM E 1646-95 (2003) C1796-1 & C1796-2

Test Number	Static Pressure Difference	Water Infiltration
	psf	
1	12*	None
2	20*	None
3	30**	None
4	50**	None

\*RollLok Seam

\*\*TripleLok Seam

**ASTM E 2140-01 (2017)** Standard Test Method for Water Penetration of Metal Panel Systems by Static 6" Water Pressure Head - PASSED with no leaks using TripleLok Seam



DESIGNING SOLUTIONS  
FOR TOMORROW



# TS-324 PERFORMANCE

## ASTM E 1592 Uplift Test Results

RollLok			
Purlin Spacing	Panel Gauge	Clip Length	Design Load
2'-0	24	4"	61.1
5'-0	24	4"	28.3
2'-0	22	4"	57.2
5'-0	22	4"	33.8

TripleLok			
Purlin Spacing	Panel Gauge	Clip Length	Design Load
2'-6	24	4"	85.5
5'-0	24	4"	42.8
2'-0	22	4"	122.5
5'-0	22	4"	44.0
2'-0	24	8"	106.0
5'-0	24	8"	51.9
2'-0	24	12"	127.8
5'-0	24	12"	61.5
2'-0	24	16"	149.7
5'-0	24	16"	71.2

QuadLok			
Purlin Spacing	Panel Gauge	Clip Length	Design Load
2'-0	24	4"	108.8
5'-0	24	4"	53.9
2'-0	22	4"	157.5
5'-0	22	4"	56.0
2'-0	24	8"	144.8
5'-0	24	8"	68.7
2'-0	24	12"	183.3
5'-0	24	12"	84.4

Design loads contain a safety factor calculated per AISI. Allowable wind uplift loads have NOT been increased by 33% as allowed by some codes when wind load controls. Test report values based on use of a BRS approved seamer.