

## PANEL CRAFT™ FC 11000 SERIES CLIP

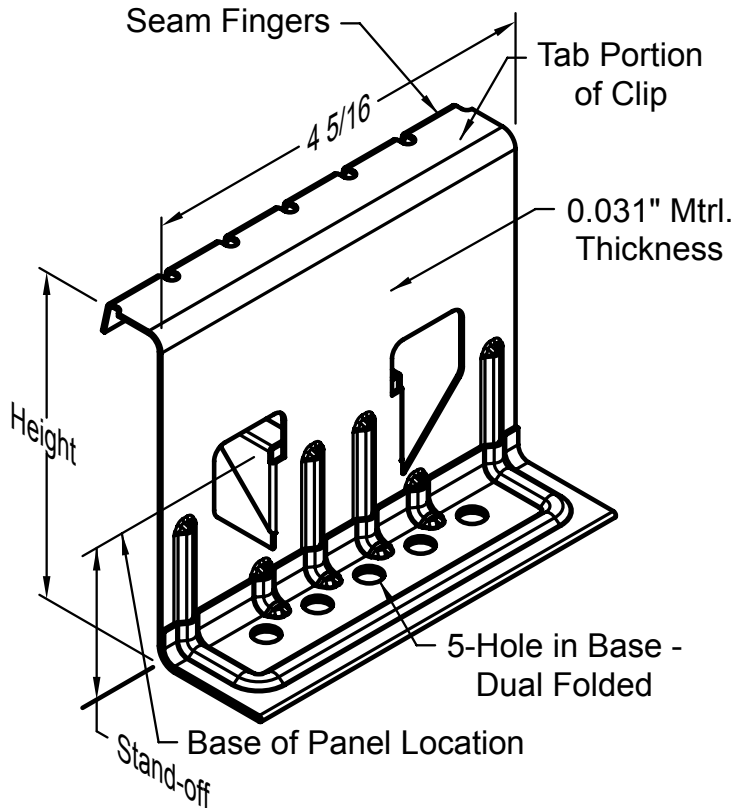

Part #	Stand-Off	Height
FC 11200	0"	2"
FC 11203	1/2"	2-1/2"
FC 11213	1-1/2"	3-1/2"

### CONSTRUCTION, TESTING, SEAMING

- G-90 Galvanized 50 ksi Steel Coating
- UL 90 Approved: Construction # 506, 506A and 506B
- ASTM E 1592 Wind Uplift Tested
- Two Mechanical seam options: TripleLok® and QuadLok®

### THERMAL MOVEMENT

- Not recommended - Max Width: 25' Plane
- Not recommended for bar joists or decking