

PANEL CRAFT™ MC 1200 SERIES MOVABLE CLIP

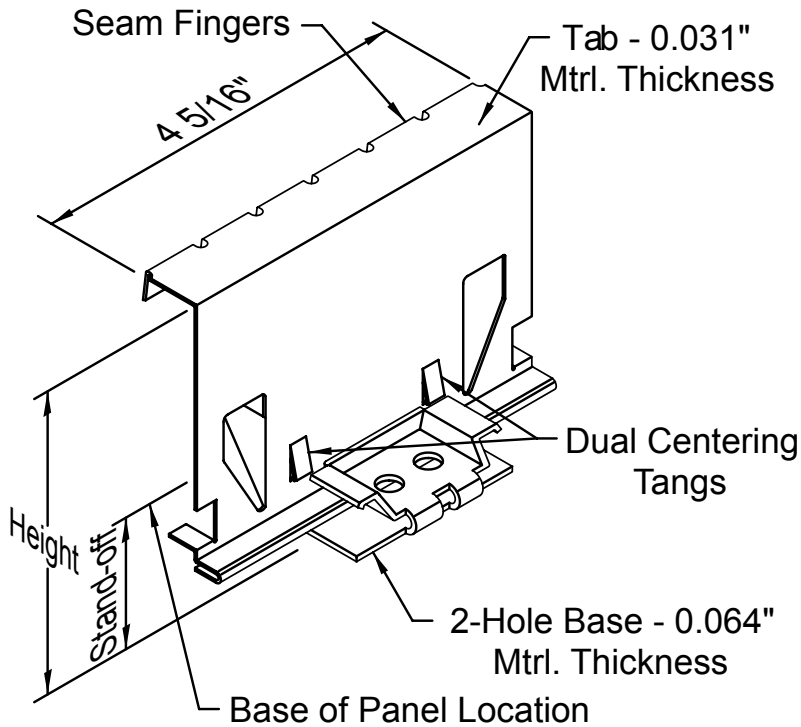

Part #	Stand-Off	Height
MC 1203	1/2"	2-1/2"
MC 1213	1-1/2"	3-1/2"

CONSTRUCTION, TESTING, SEAMING

- G-90 Galvanized 50 ksi Steel Coating
- Centering Tangs
 - Fixed at center for installation
 - Free thermal movement after installation
- UL 90 Approved: Construction # 506, 506A and 506B
- ASTM E 1592 Wind Uplift Tested
- Two Mechanical Seam Options: TripleLok® and QuadLok®

THERMAL MOVEMENT

Clip Part #	Base Holes	Slide One Way	Maximum Length Plane Without Expansion Design		
			Temp Diff 100 degrees	Temp Diff 125 degrees	Temp Diff 150 degrees
MC 1203	2	1.325	170' - 0"	135' - 0"	115' - 0"



The Superior Seam Technology design and engineering meets the more stringent corner/edge zones uplift codes.