

## TS 324 MPS 60X SERIES MOVABLE PURLIN STABILIZING CLIP

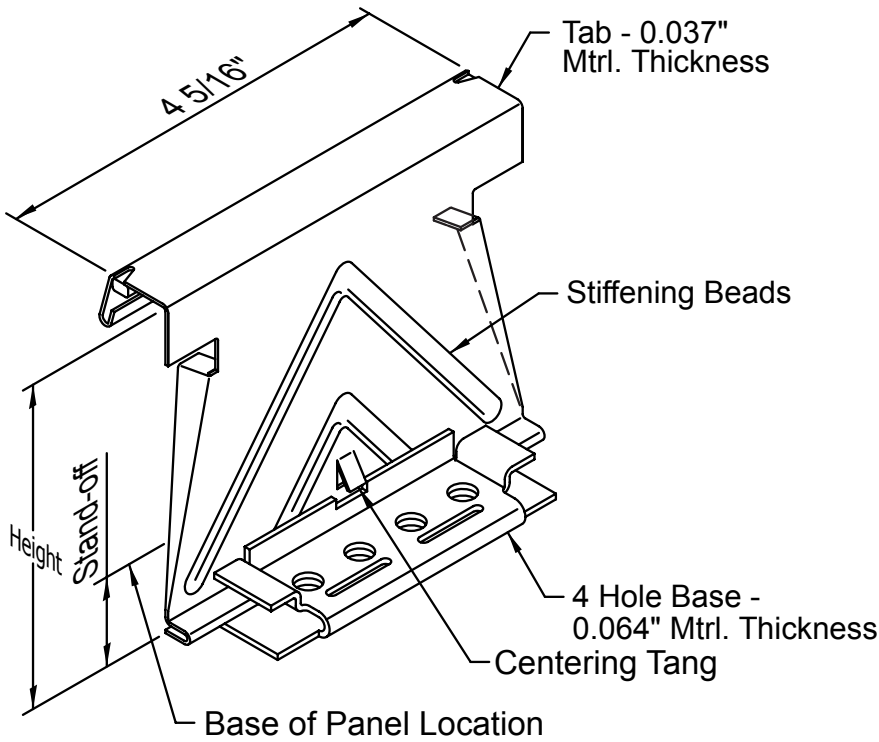

Part #	Stand-Off	Height
MPS 602	1/2"	3-1/2"
MPS 603	1-1/2"	4-1/2"

### CONSTRUCTION, TESTING, SEAMING

- G-90 Galvanized 50ksi Steel Coating
- Centering Tang:
  - Fixed at center for installation
  - Free thermal movement after installation
- UL 90 Approved: Construction # 552, 552A and 552B
- ASTM E 1592 Wind Uplift Tested
- Three mechanical Seaming Options: RollLok®, TripleLok® and QuadLok®

### THERMAL MOVEMENT

Clip Part #	Base Holes	Slide One Way	Maximum Length Plane Without Expansion Design		
			Temp Diff 100 degrees	Temp Diff 125 degrees	Temp Diff 150 degrees
MPS 60X Series	4	1.625	210' - 0"	165' - 0"	140' - 0"



The Superior Seam Technology design and engineering meets the more stringent corner/edge zones uplift codes.